

LZB-300-R5 Cubic Shape Vacuum Packer

i. Applications

Used for the quantitative brick shape vacuum packaging in the industry of rice, grains, peanuts, and food etc.

ii. Technical parameters:

Model	LZB-300-R5
Weighing extent (kg)	0.5-5
Speed(bags/h)	300-360
Scale Interval(gram)	1
Precession grade	X(0.5)
Power	4N-AC 380V 50Hz 4.0KW
Air , air consumption	0.4-0.6MPa 3m ³ /h(supplied by the customer)
Height (mm)	2400

iii. Main Configures:

NO.	Name:	Main Configures
1	Touch screen 7"	Japan / Omron
2	Weighing controller	Canada/General
3	PLC	Japan / Omron
4	Switching Power Supply	Japan / Omron
5	Solid state relay	Japan / Omron
6	Intermediate relay	Japan / Omron
7	Load cell	USA/VPG
8	Phase sequence protection relay	France / Schneider
10	Vacuum pump	Germany/ (BECKER)
11	Cylinder	Taiwan /Airtac
12	Solenoid valve	Taiwan /Airtac
13	Linear Slides	Taiwan/ABBA

iv. Functions and Features

- New generation of high-speed weighing control mode parameter automatic correction, adaptive weighing process various materials;
- Omron touch screen, Omron PLC centralized control, intelligent control weighing, filling, six-sided plastic,
- Vacuum, heat sealing, unloading bags, the whole process of transportation, real-time tracking system working state, friendly interface, easy to operate;
- imported from Japan, Airtac pneumatic components, high reliability and long service life;
- imported from Germany, vacuum pumps, stable and reliable;
- device with fault self-test function, maintenance is simple and convenient;
- intelligent control information presentation system;
- Automatic Bag interface reserved.
- Reserve RS232/485



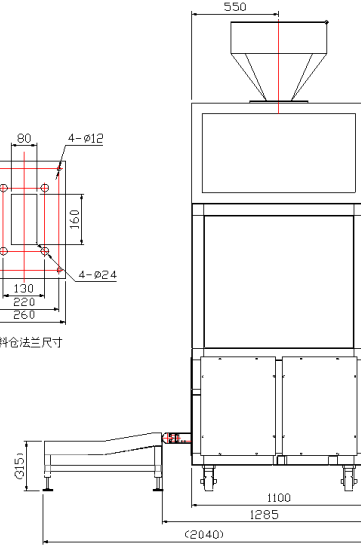
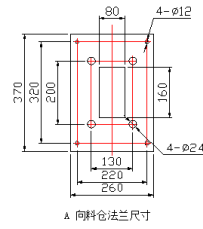
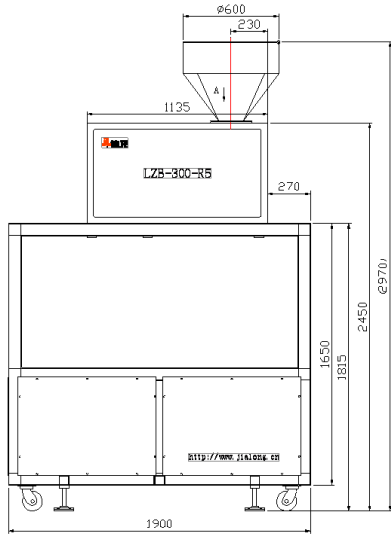

										漳州佳龙 科技股份有限公司		
										产品安装图		
										LZB-300-R5		
标记	处数	分区	更改文件号	签名	年、月、日	阶段标记		数量	比例			
设计			标准化			B		1	1:20			
审核												
工艺			批准							共 1 张 第 1 张		